

Dominik Schumacher, Michael A. Herzog
Winckelmann interaktiv



Festwoche zum 300. Geburtstag von Johann Joachim Winckelmann,
6.12.2017, Audimax, Hochschule Magdeburg-Stendal

»» PRODUCT ««

Feasibility
Implementation



Form + Function
Interaction
Attractiveness

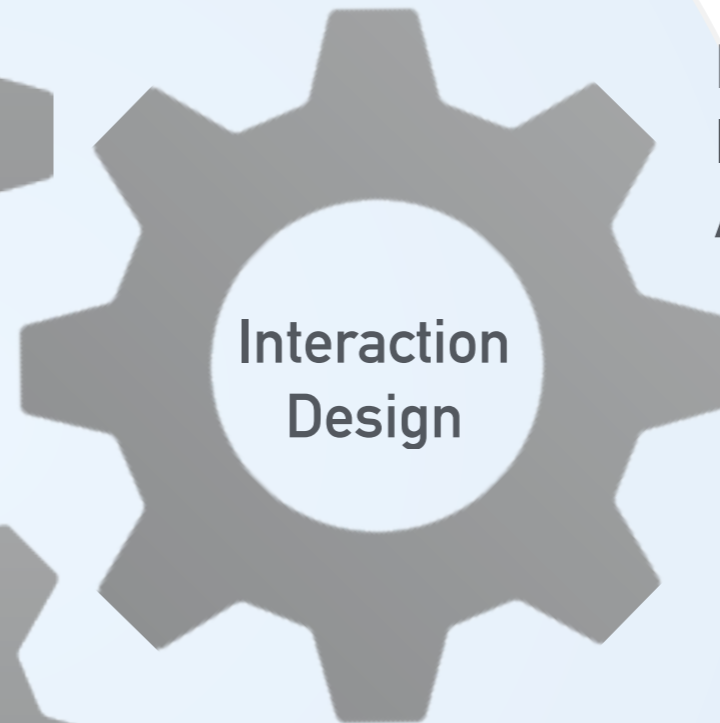

Markets
Processes
Efficiency
Social fit



Nominal process sequence

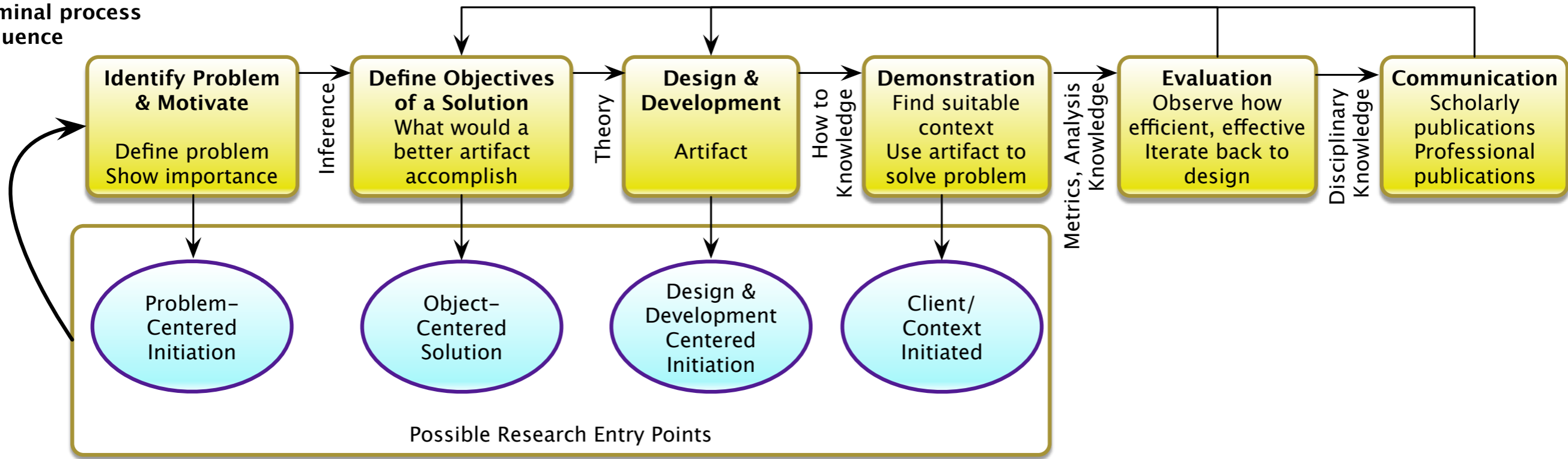

Peppers, K., Tuunanen, T., Rothenberger, M. A., & Chatterjee, S. (2007). A design science research methodology for information systems research. *Journal of management information systems*, 24(3), 45-77.

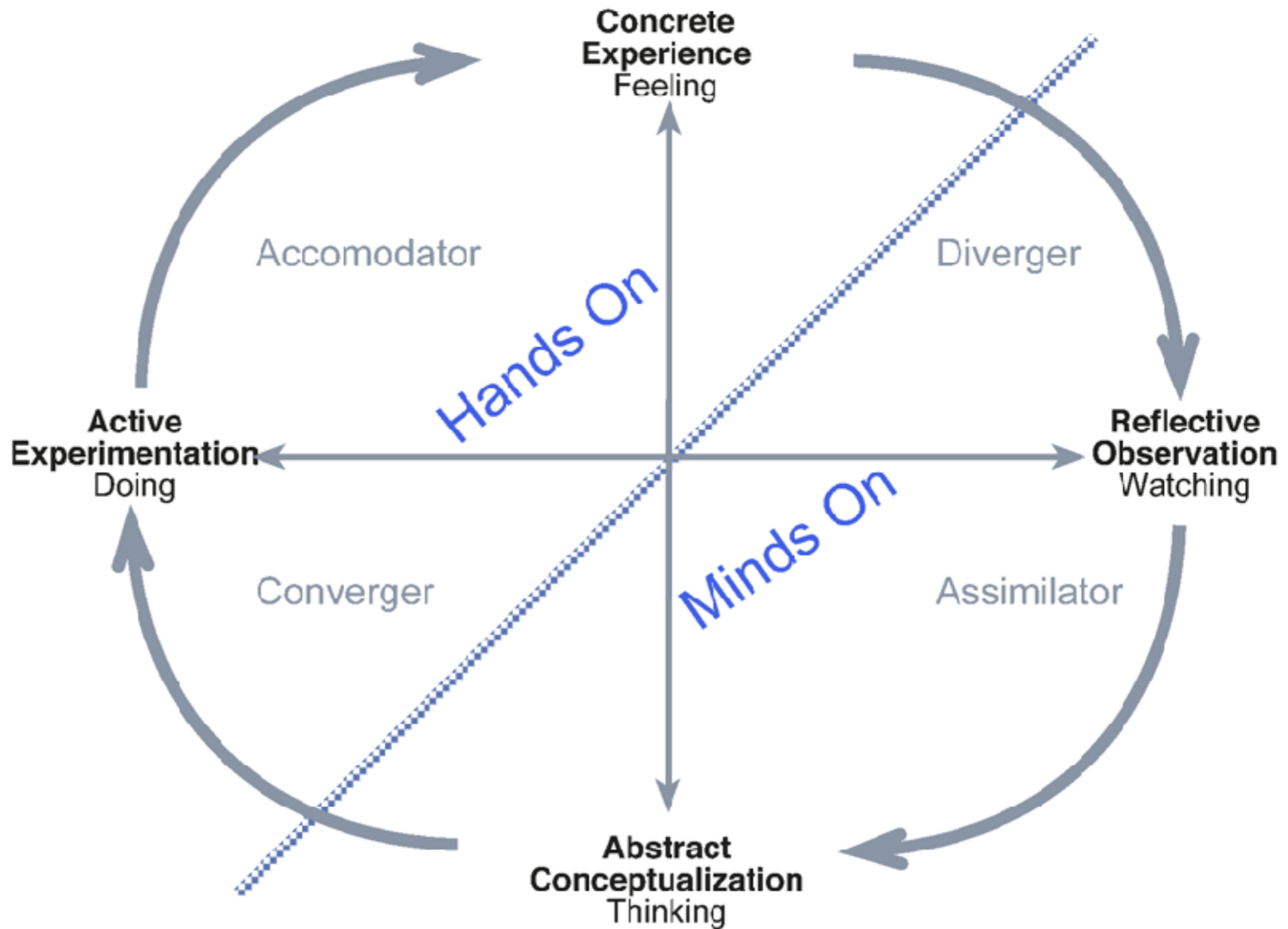

Kolb, D. A. (1984) *Experiential Learning: Experience as the Source of Learning and Development*, Prentice-Hall, Inc., Englewood Cliffs, N.J.

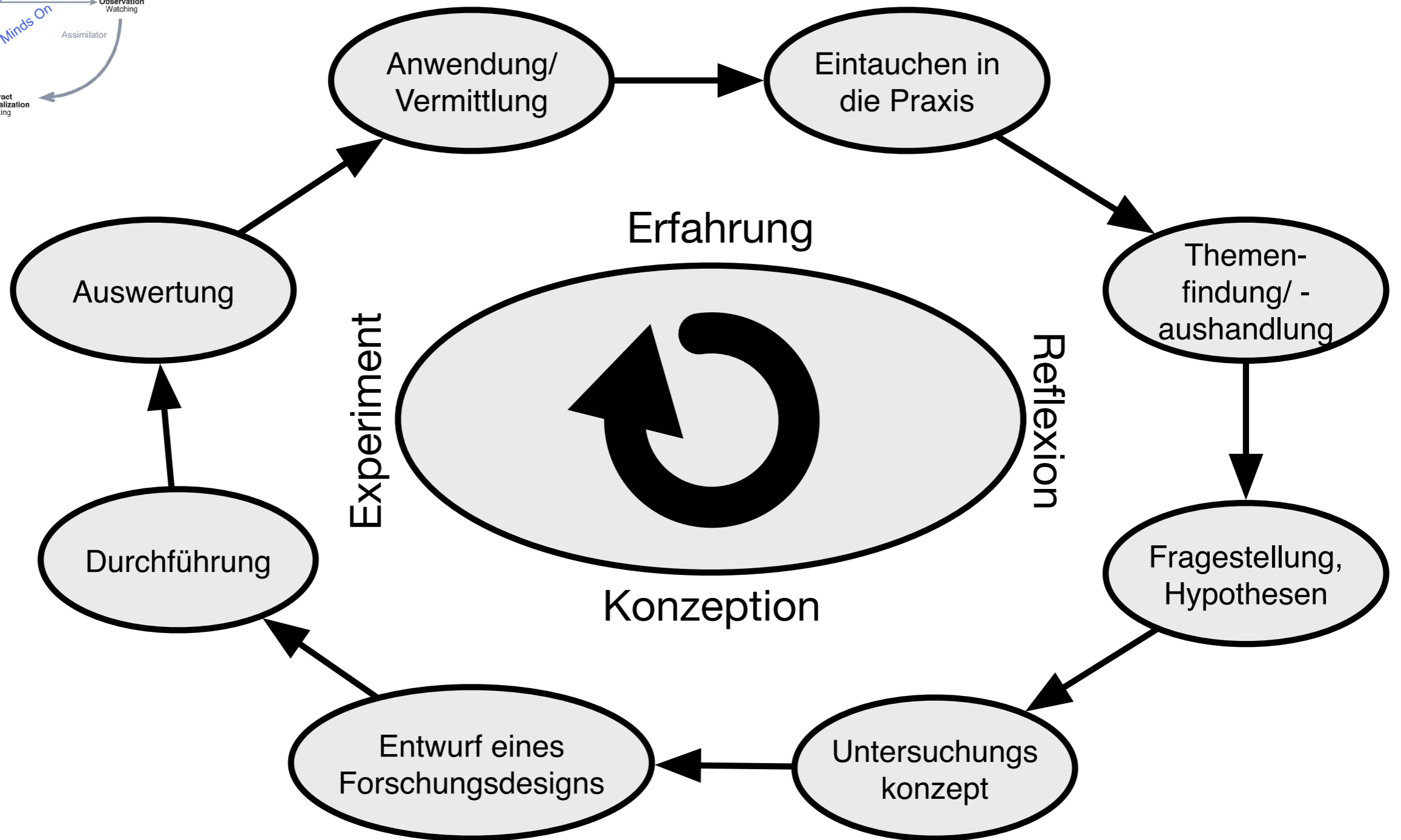
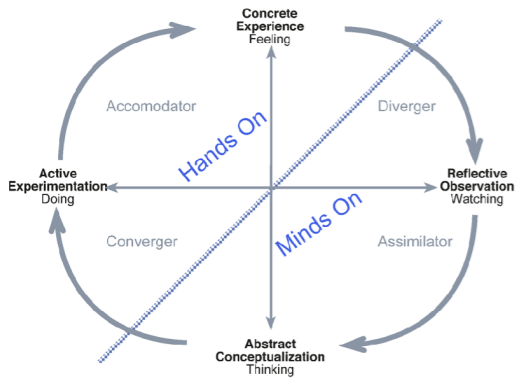

Wildt, J.: Forschendes Lernen: Lernen im „Format“ der Forschung. journal hochschuldidaktik, 20 (2), 2009, S 4-7



Project Extended Exhibition, Jens Wunderling, Michael Herzog et. al. 2016 • L.U.M.E.N Mareike Gabele, Robert Klank, Nicolas Pepping, Eric Schmieder

»Forschendes Lernen« – Wirtschaftliche Verwertung – Service Systems Engineering

Dienstleistungssystem

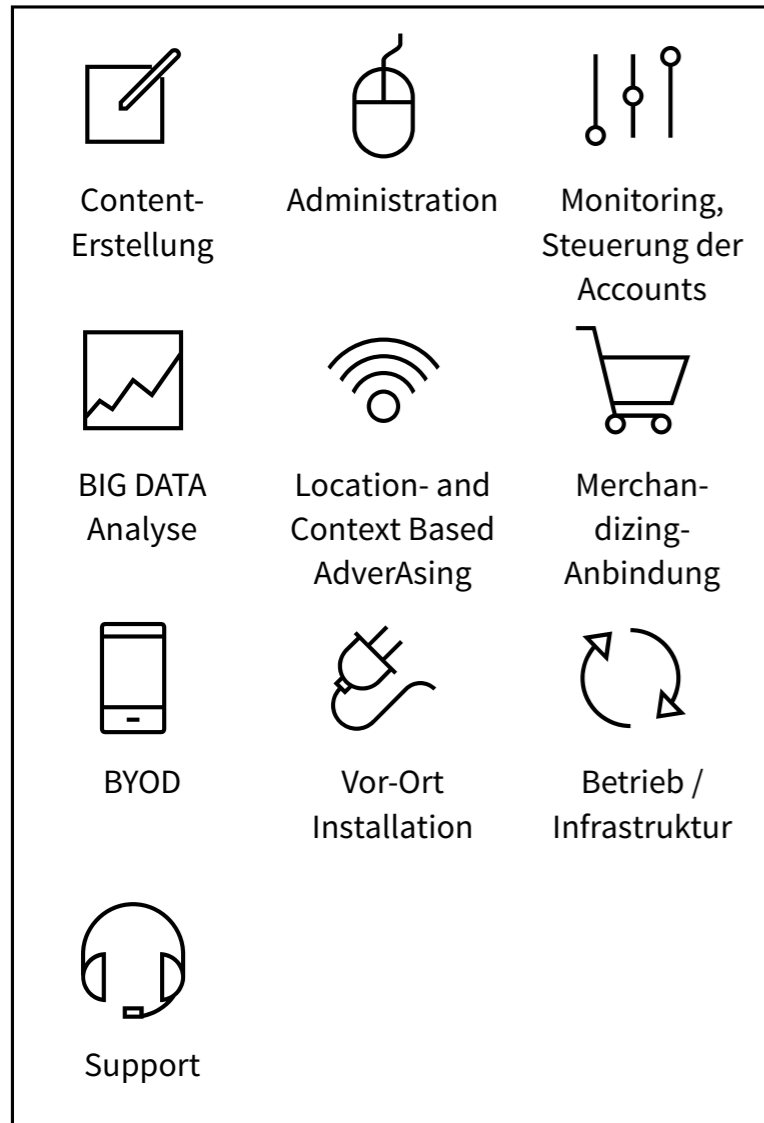

Kernkompetenzen

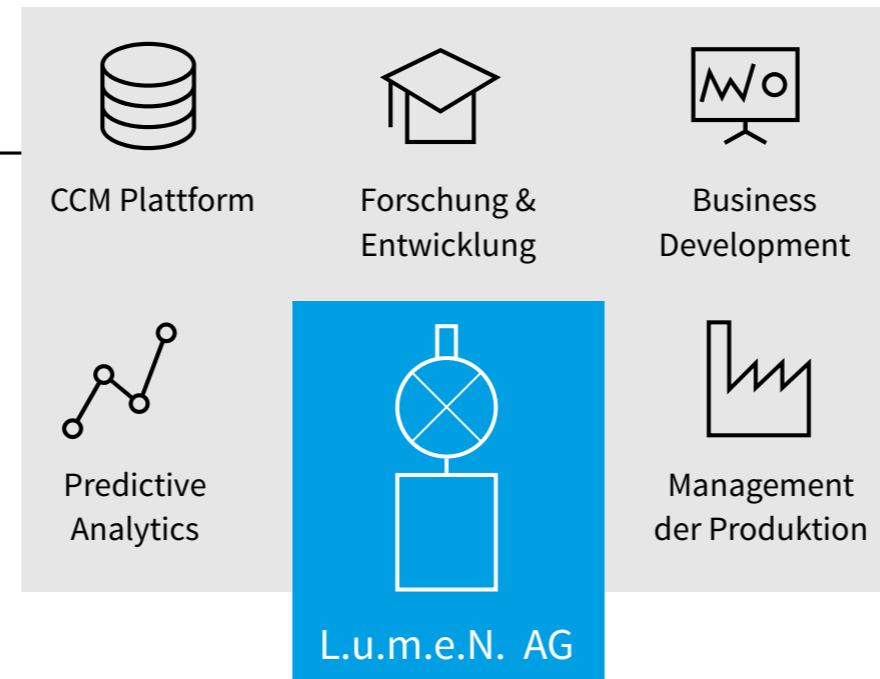

Basisleistungen Outsourcing

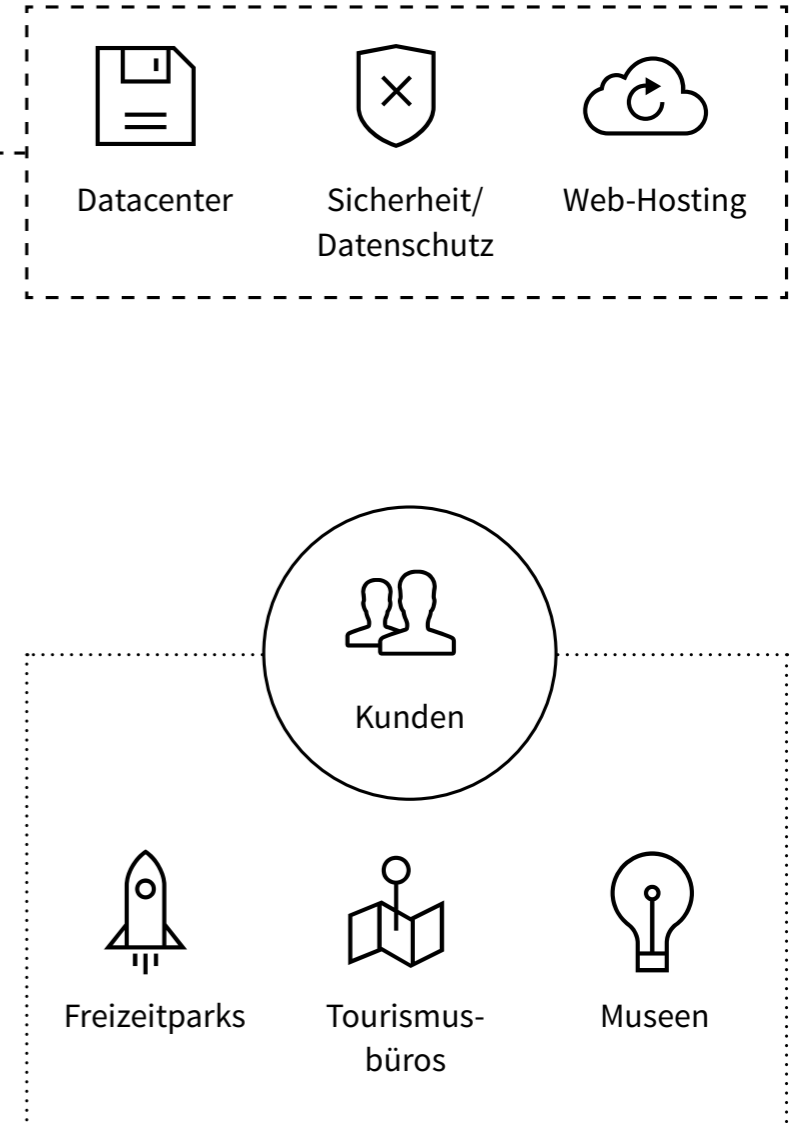

Project Extended Exhibition, Jens Wunderling, Michael Herzog et. al. 2016
 L.U.M.E.N Mareike Gabele, Robert Klank, Nicolas Pepping, Eric Schmieder

		Malerczyk, 2004 [8]	Rudametkin, et al, 2008 [7]	Zabulis, et al., 2010 [9]	Suh, et al., 2011 [6]	Rocchetti, et al., 2014 [14]	Tesoriero, et al., 2014 [5]	Bohnert, et al., 2014 [10]	Confalonieri, et al., 2015 [12]	Alletto et al., 2016 [11]	L.U.M.E.N	I.D.C.	S.I.V.E.	Connectibition
Seamless integration	use of mobile devices / BYOD		■		■	■	■				■	■		
	seamless integration of technology	■		■							■	■	■	■
	explorative access to information	■		■	■		■			■	■		■	■
	navigation support						■				■			
User Experience / Personalization	influence / communicate with exhibits			■							■	■	■	■
	adjustment to needs of individual user	■		■			■	■		■		■		
	personal configuration using locating technology		■	■			■	■		■	■	■	■	■
	addressing specific target groups		■	■							■	■		
	narration / storytelling	■		■							■		■	
	establishing connection between subjects	■												■
Expanding exhibition space	access to new kinds of exhibition formats			■			■				■		■	■
	reactive / interactive exhibition ground			■								■	■	■

Herzog, M.A., Wunderling, J., Gabele, M., Klank, R., Landenberger, M., Pepping, N.: Context Driven Content Presentation for Exhibition Places. Four Interaction Scenarios Developed for Museums. Electronic Imaging & the Visual Arts Conference EVA 2016, St. Petersburg



»The Third Mission«

WINCKELMANN
MUSEUM



Wissenschaft ist
dem zugänglicher
(nach Newton)

Bibel steht im
Mittelpunkt

Philosophen:
• François-Marie
Arouet Voltaire
• Denis Diderot
• Erasmus Darwin

aufstrebendes
Bürgertum,
das mitbestimmen
will

Aufklärung

AUFKLÄRUNG

Winckelmanns
Beschreibung von Objekten
- nach dem Geiste
- harmonische Schönheit
- Einfachheit
- Darstellung der Schönheit
- allgemein
- einfach

1720 FRÜH BAROCK

ROCKOKO / SPÄT BAROCK

1720

1770

1717

1768

literarischer Stil
in der Barockzeit

- religiös determiniert, nach bestimmten Regeln, die für diese Zeit üblich waren
- Gegenständliche Auseinandersetzung
- Vergänglichkeit - Evangelium durch Krieg, Pest & Gottesknecht (Mahl)
- Mythologisch-religiöse Schmuckmal & fantastische Gestalten

WINCKELMAN

1774

Ständigkeit
Persönlichkeit
Vernunft
Wissenschaften
Lebenswandel

Die Frau - Bekleidung im Barock



Die Frau - Bekleidung im Rokoko



Stoffe und Farben im Rokoko



Der Mann - Bekleidung im Barock





»Rapporto« – das Leben des J. Winckelmann

Project WINCKELMANN INTERACTIVE, Dominik Schumacher, Michael Herzog et. al. 2017
RAPPORTO Anja Weigl, Robert Wlcek, Marc Rabsilber



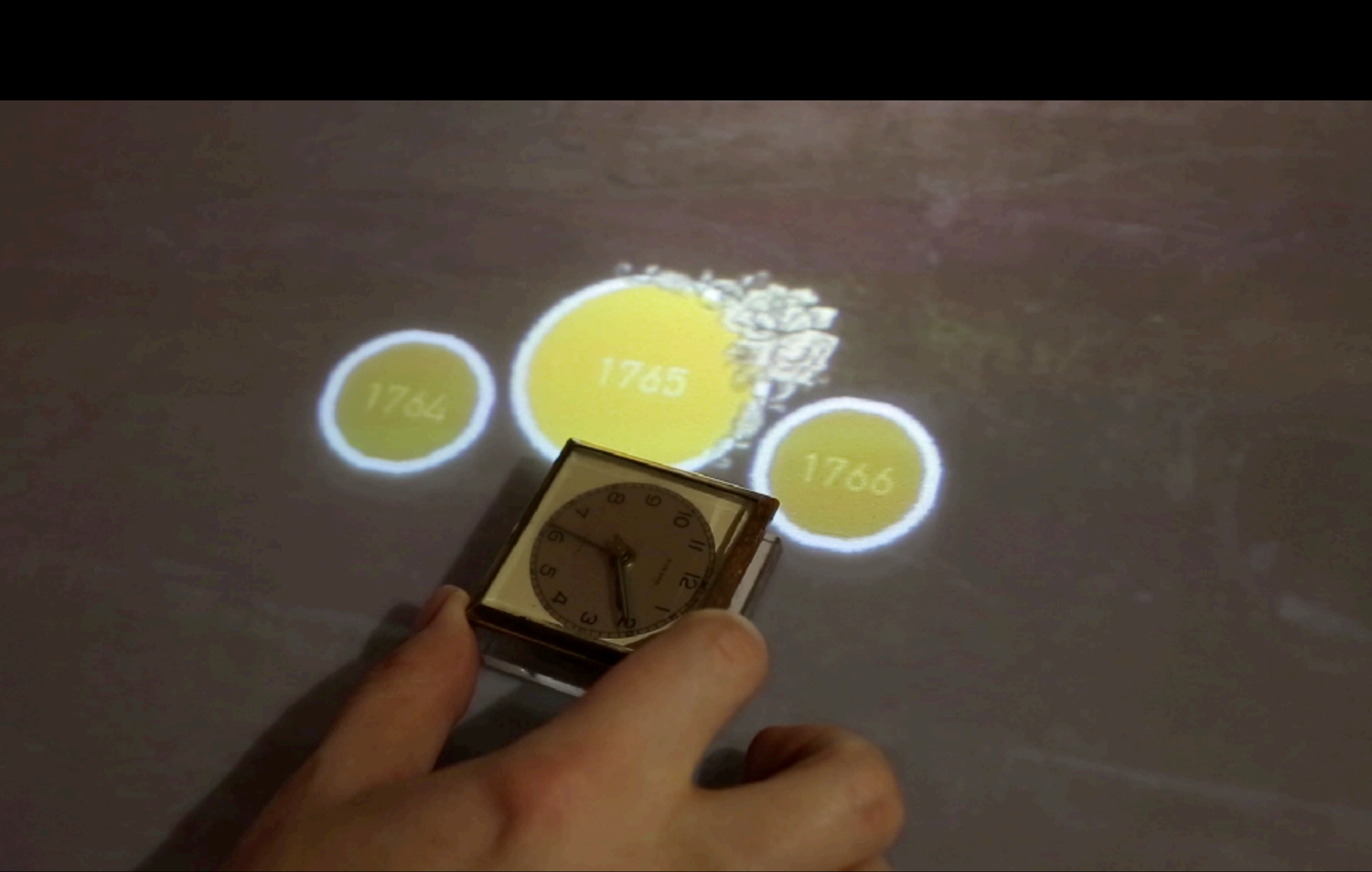

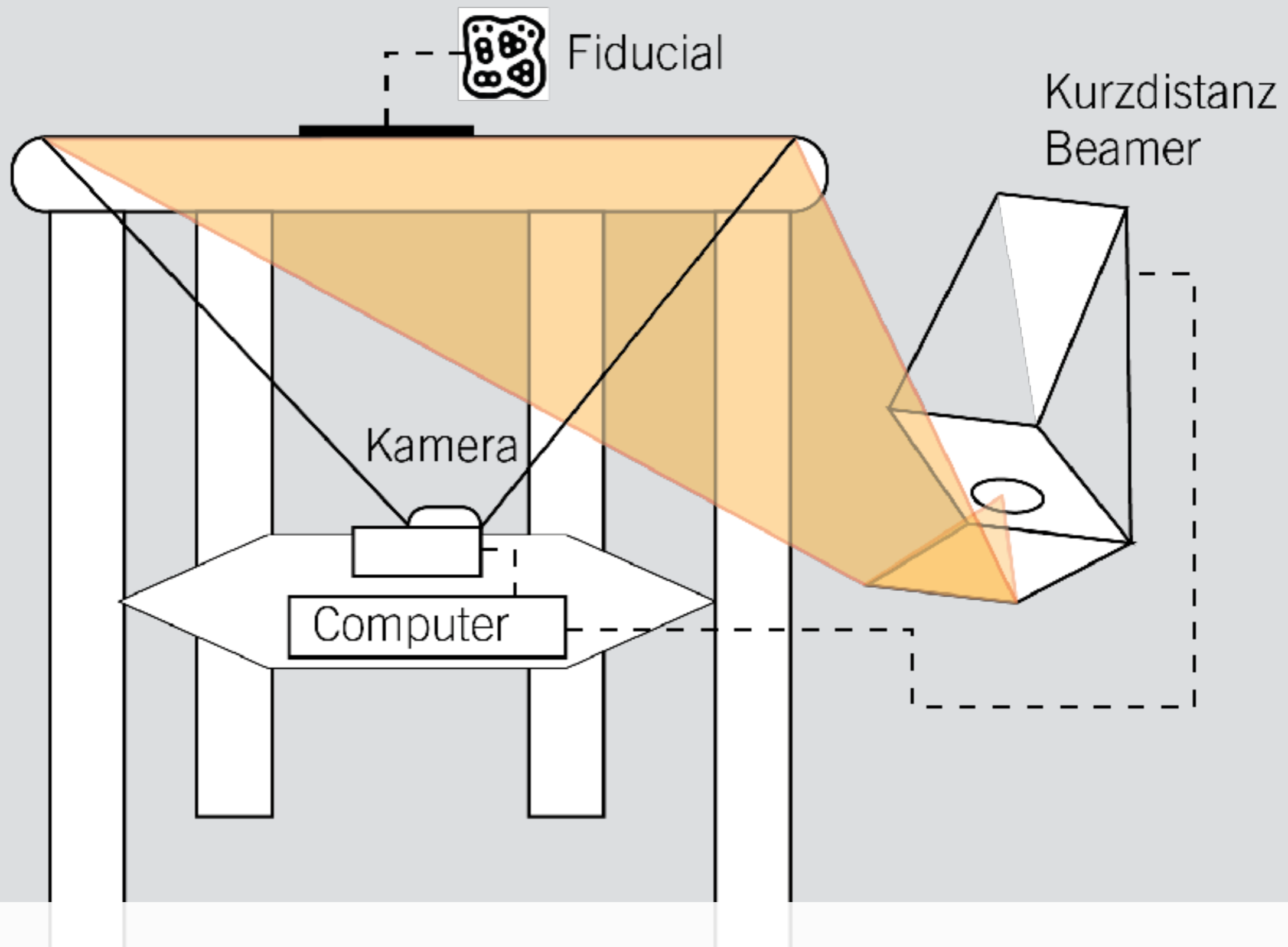





»Spendenbox« – die Geldnöte des J. Winkelmann

Project WINCKELMANN INTERACTIVE, Dominik Schumacher, Michael Herzog et. al. 2017
GIFTBOX Julian Solisch., Martin Schreier, Oliver Krüger, Martin Szemkus

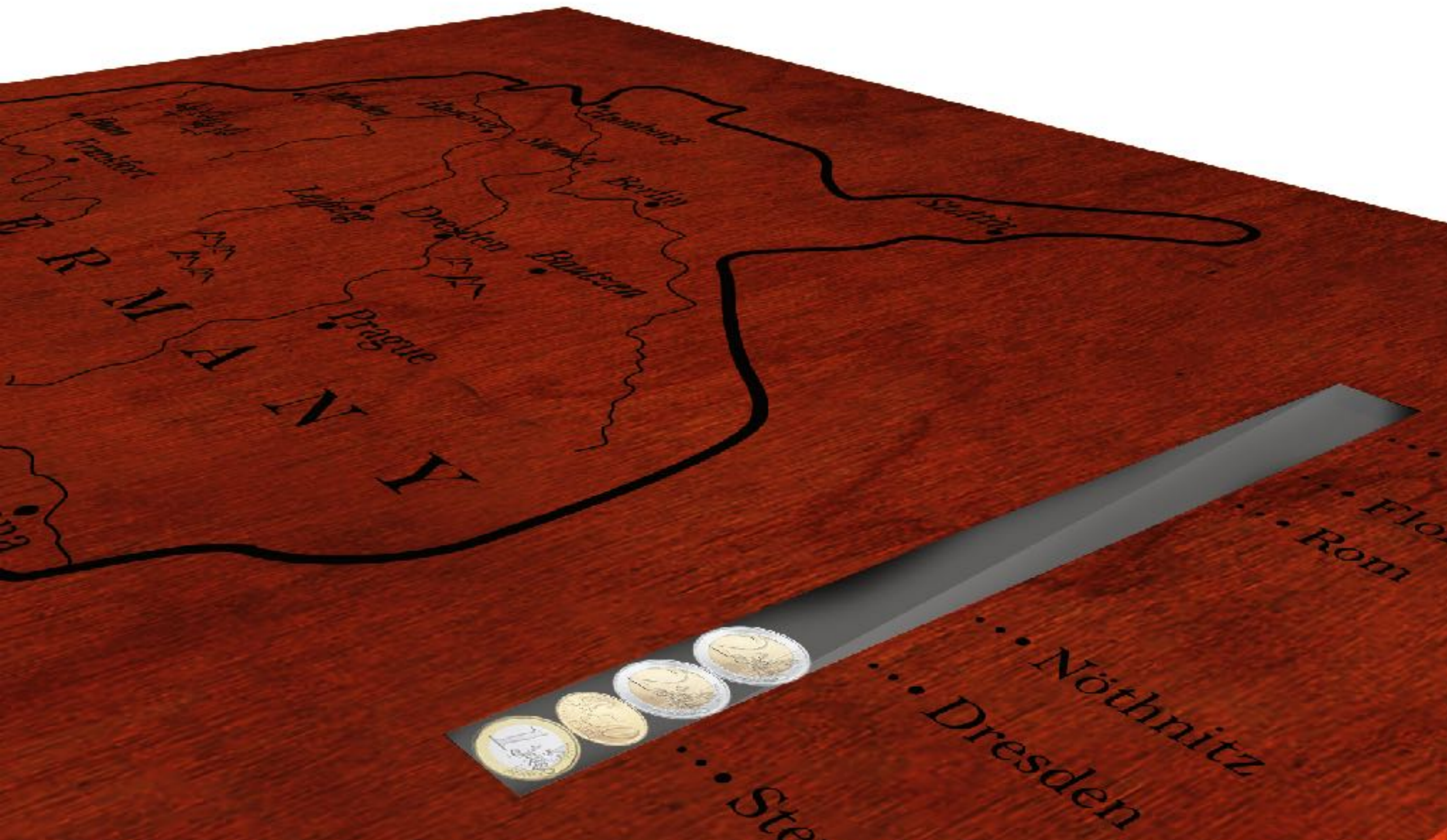

»Spendenbox« – die Geldnöte des J. Winkelmann

Project WINCKELMANN INTERACTIVE, Dominik Schumacher, Michael Herzog et. al. 2017
GIFTBOX Julian Solisch., Martin Schreier, Oliver Krüger, Martin Szemkus



»Spendenbox« – die Geldnöte des J. Winkelmann

Project WINCKELMANN INTERACTIVE, Dominik Schumacher, Michael Herzog et. al. 2017
GIFTBOX Julian Solisch., Martin Schreier, Oliver Krüger, Martin Szemkus



Wilhelm Tappert
Rektor der Schule

„Der kleine Johann
Joachim ist mir in
der Zeit zur Hand ge-
gangen. Dafür habe
ich ihn über die Schule
hinaus gefördert.“

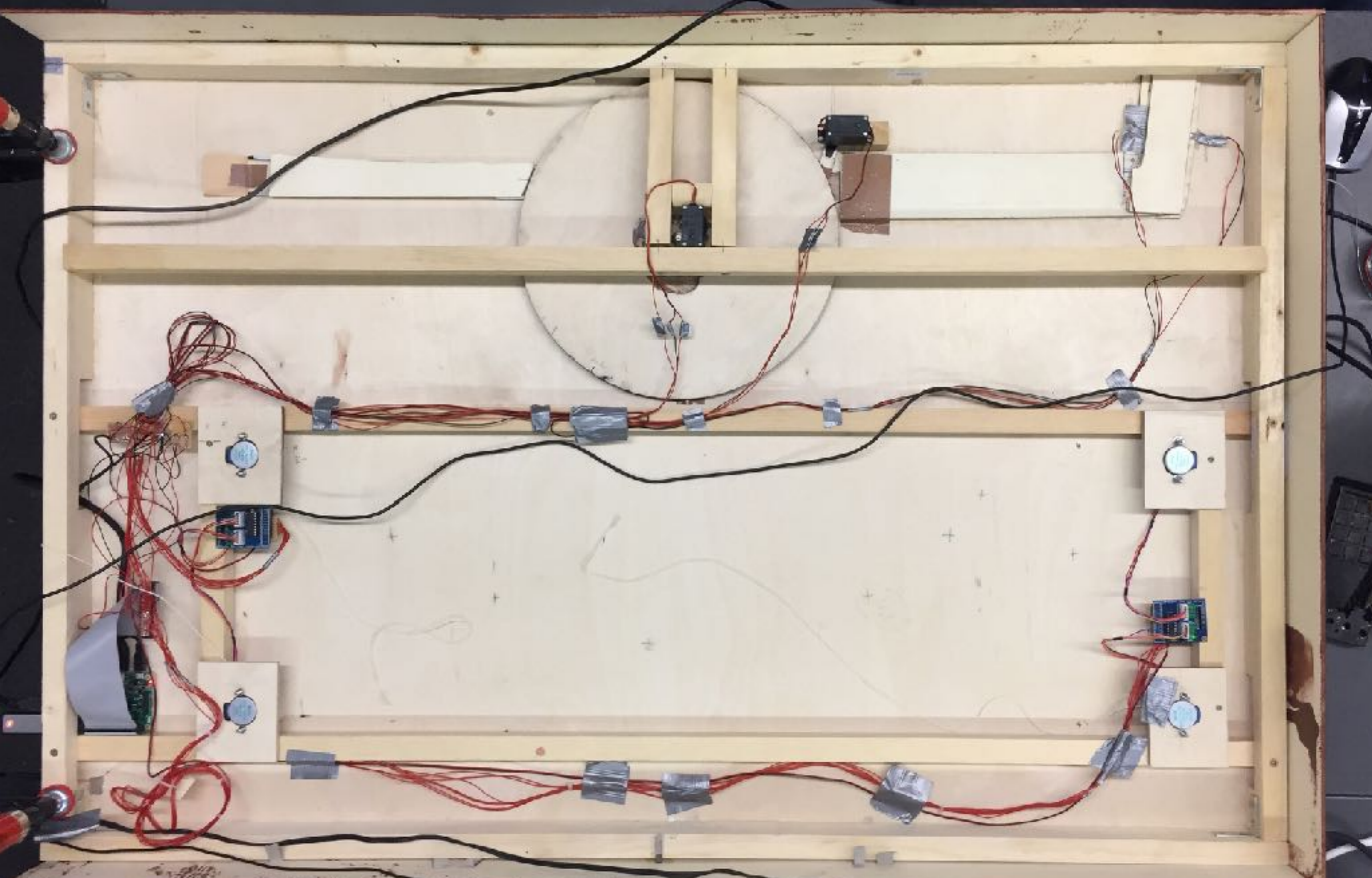



»Spendenbox« – die Geldnöte des J. Winkelmann

Project WINCKELMANN INTERACTIVE, Dominik Schumacher, Michael Herzog et. al. 2017
GIFTBOX Julian Solisch., Martin Schreier, Oliver Krüger, Martin Szemkus



»Der Torso von Belvedere« – das Werk des J. Winkelmann

Project WINCKELMANN INTERACTIVE,
Dominik Schumacher, Michael Herzog et. al. 2017
AUGMENTED ARTWORK: THE TORSO OF BELVEDERE
Victoria Batz, Finn Blümel, Jonas Falkenberg, Elisa Haubert



»Der Torso von Belvedere« – das Werk des J. Winkelmann

Project WINCKELMANN INTERACTIVE,
Dominik Schumacher, Michael Herzog et. al. 2017
AUGMENTED ARTWORK: THE TORSO OF BELVEDERE
Victoria Batz, Finn Blümel, Jonas Falkenberg, Elisa Haubert



»Der Torso von Belvedere« – das Werk des J. Winkelmann

Project WINCKELMANN INTERACTIVE,
Dominik Schumacher, Michael Herzog et. al. 2017
AUGMENTED ARTWORK: THE TORSO OF BELVEDERE
Victoria Batz, Finn Blümel, Jonas Falkenberg, Elisa Haubert



»Der Torso von Belvedere« – das Werk des J. Winkelmann

Project WINCKELMANN INTERACTIVE,
Dominik Schumacher, Michael Herzog et. al. 2017
AUGMENTED ARTWORK: THE TORSO OF BELVEDERE
Victoria Batz, Finn Blümel, Jonas Falkenberg, Elisa Haubert



»Der Torso von Belvedere« – das Werk des J. Winkelmann

Project WINCKELMANN INTERACTIVE,
Dominik Schumacher, Michael Herzog et. al. 2017
AUGMENTED ARTWORK: THE TORSO OF BELVEDERE
Victoria Batz, Finn Blümel, Jonas Falkenberg, Elisa Haubert

MENTED ARTWORK
RSO VOM BELVEDERE

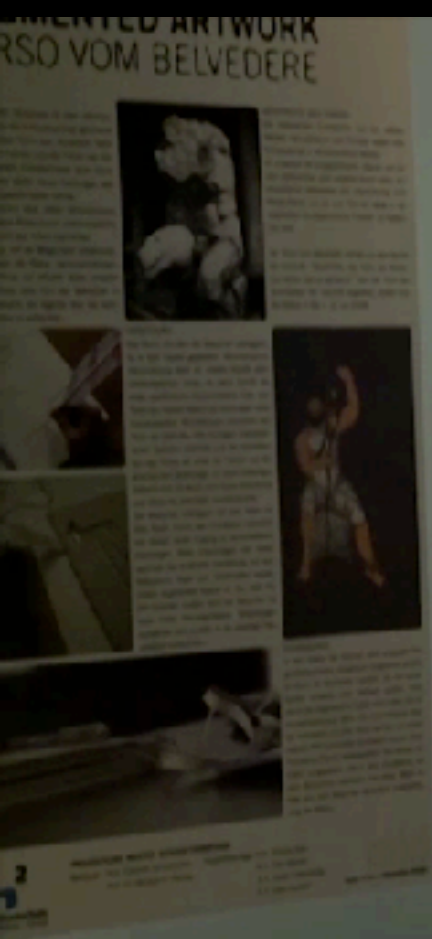

Project WINCKELMANN INTERACTIVE,
Dominik Schumacher, Michael Herzog et. al. 2017
AUGMENTED ARTWORK: THE TORSO OF BELVEDERE
Victoria Batz, Finn Blümel, Jonas Falkenberg, Elisa Haubert



»Der Torso von Belvedere« – das Werk des J. Winkelmann

Project WINCKELMANN INTERACTIVE,
Dominik Schumacher, Michael Herzog et. al. 2017
AUGMENTED ARTWORK: THE TORSO OF BELVEDERE
Victoria Batz, Finn Blümel, Jonas Falkenberg, Elisa Haubert



»MemoryStamp« – die Sammelleidenschaft des J. Winkelmann

Project WINCKELMANN INTERACTIVE,
Dominik Schumacher, Michael Herzog et. al. 2017
MEMORY STAMP Su Yi, Wanting Sun

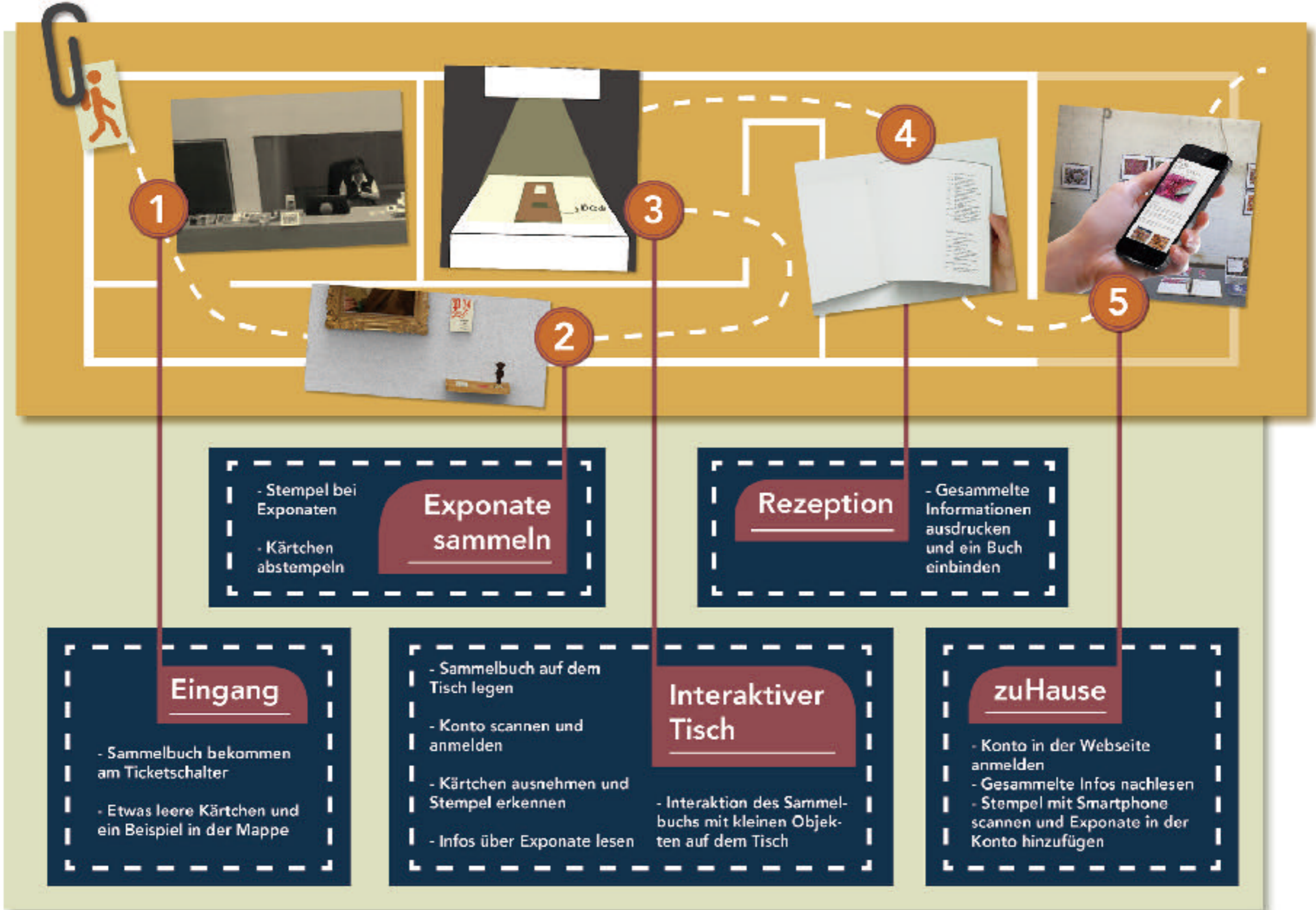



»MemoryStamp« – die Sammelleidenschaft des J. Winkelmann

Project WINCKELMANN INTERACTIVE,
Dominik Schumacher, Michael Herzog et. al. 2017
MEMORY STAMP Su Yi, Wanting Sun



»MemoryStamp« – die Sammelleidenschaft des J. Winkelmann

Project WINCKELMANN INTERACTIVE,
Dominik Schumacher, Michael Herzog et. al. 2017
MEMORY STAMP Su Yi, Wanting Sun



»MemoryStamp« – die Sammelleidenschaft des J. Winkelmann

Project WINCKELMANN INTERACTIVE,
Dominik Schumacher, Michael Herzog et. al. 2017
MEMORY STAMP Su Yi, Wanting Sun

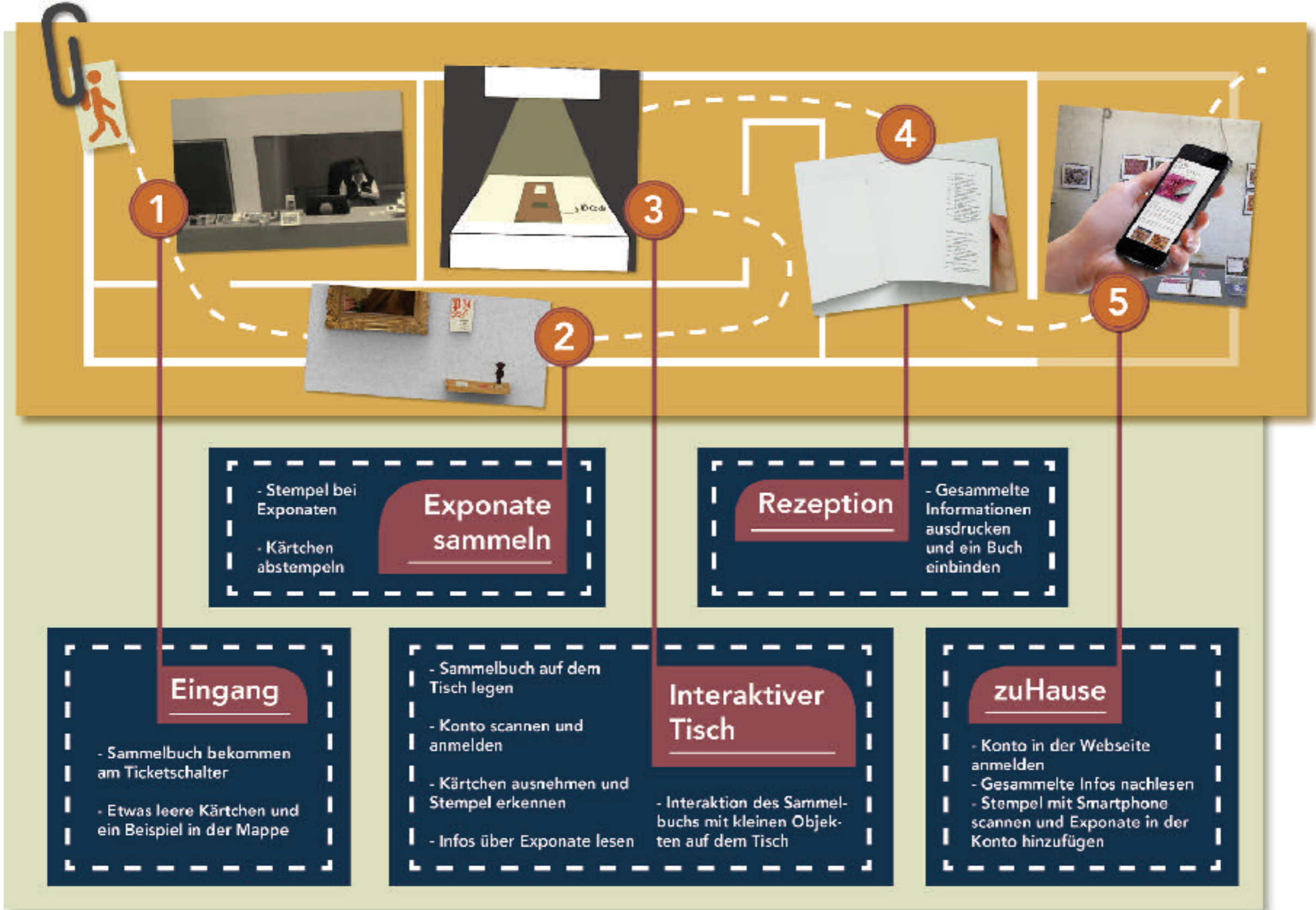



»MemoryStamp« – die Sammelleidenschaft des J. Winkelmann

Project WINCKELMANN INTERACTIVE,
Dominik Schumacher, Michael Herzog et. al. 2017
MEMORY STAMP Su Yi, Wanting Sun



»MemoryStamp« – die Sammelleidenschaft des J. Winkelmann

Project WINCKELMANN INTERACTIVE,
Dominik Schumacher, Michael Herzog et. al. 2017
MEMORY STAMP Su Yi, Wanting Sun

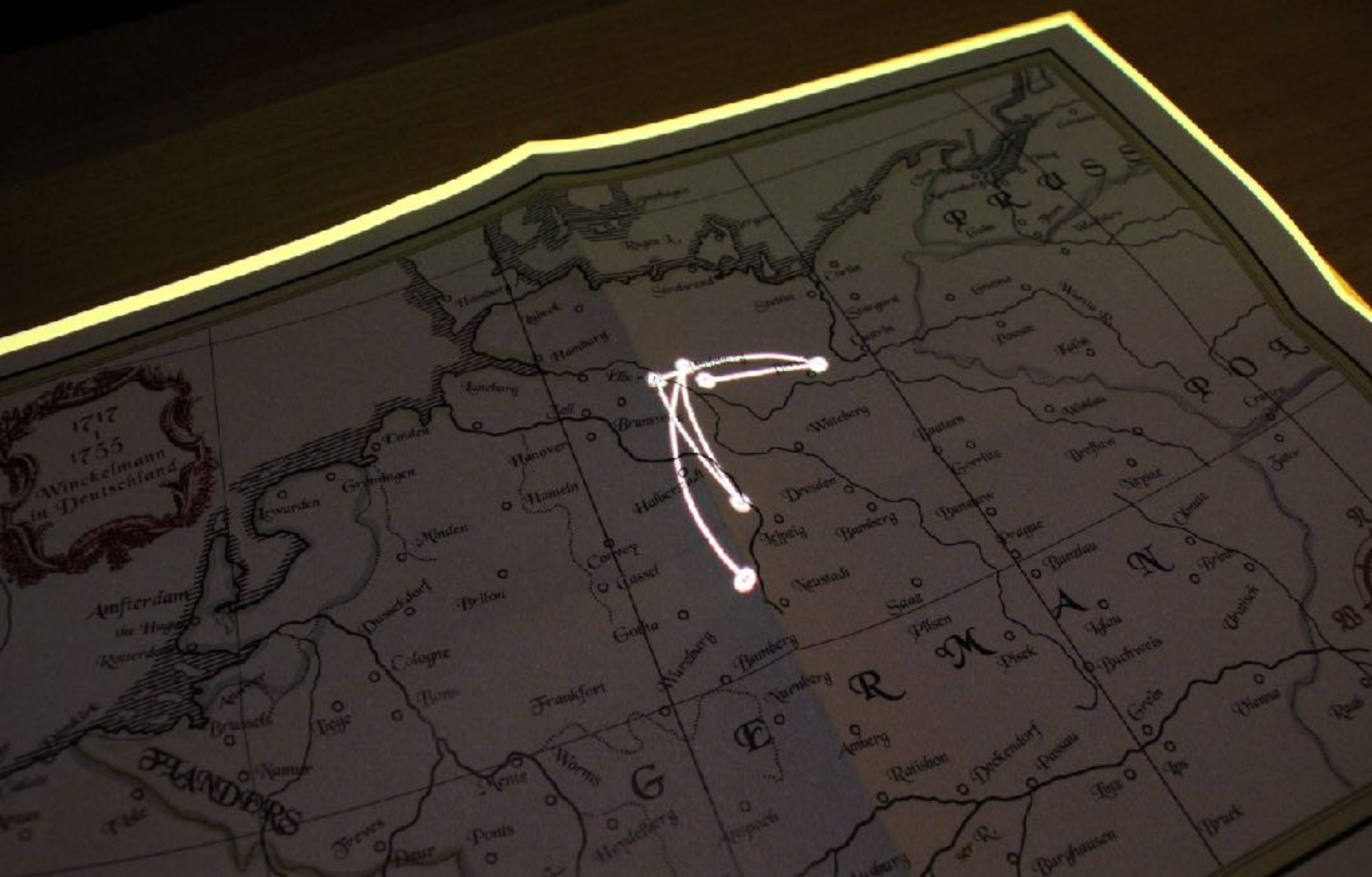

»MemoryStamp« – die Sammelleidenschaft des J. Winckelmann

Project WINCKELMANN INTERACTIVE,
Dominik Schumacher, Michael Herzog et. al. 2017
MEMORY STAMP Su Yi, Wanting Sun





»MemoryStamp« – die Sammelleidenschaft des J. Winkelmann

Project WINCKELMANN INTERACTIVE,
Dominik Schumacher, Michael Herzog et. al. 2017
MEMORY STAMP Su Yi, Wanting Sun

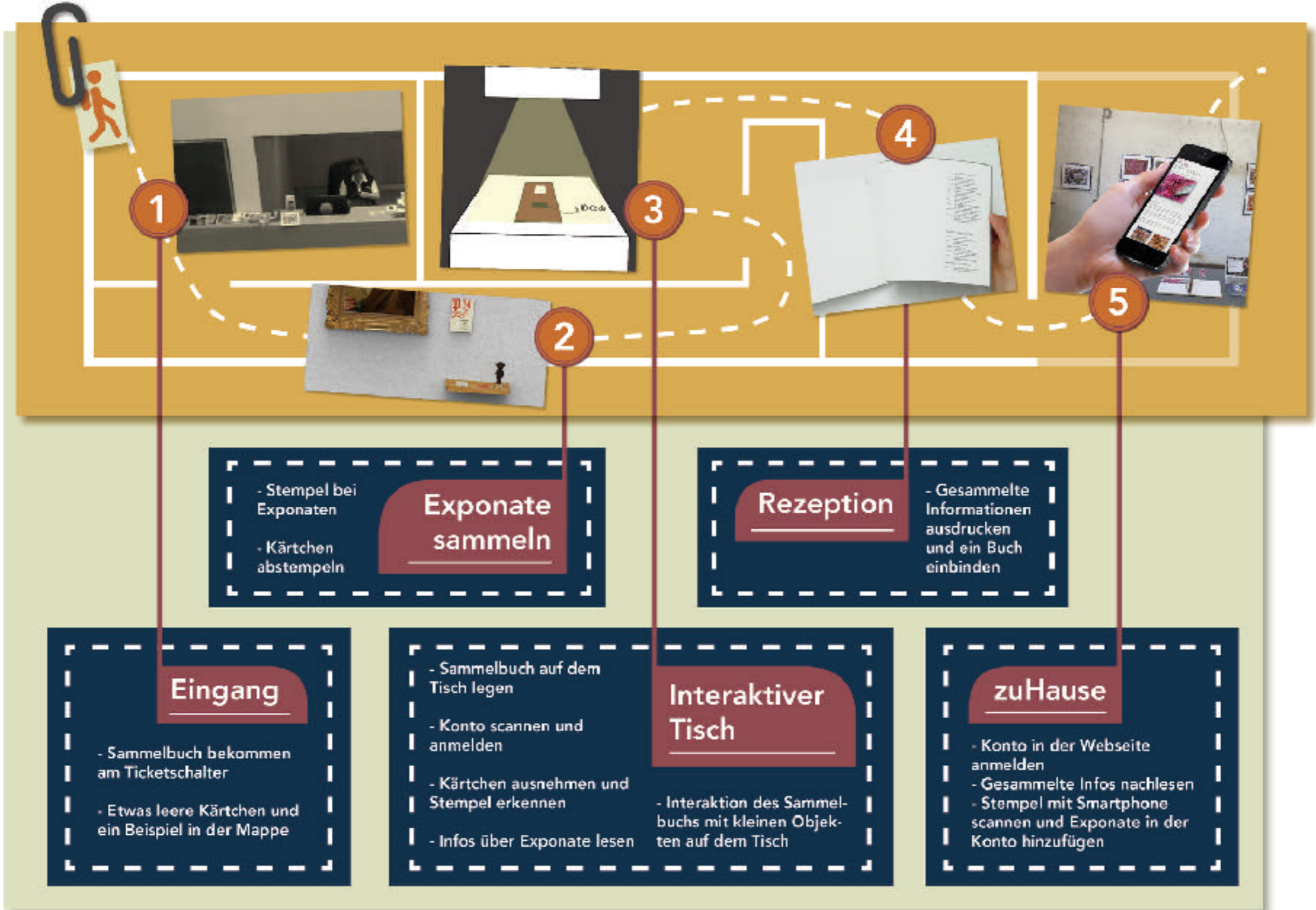

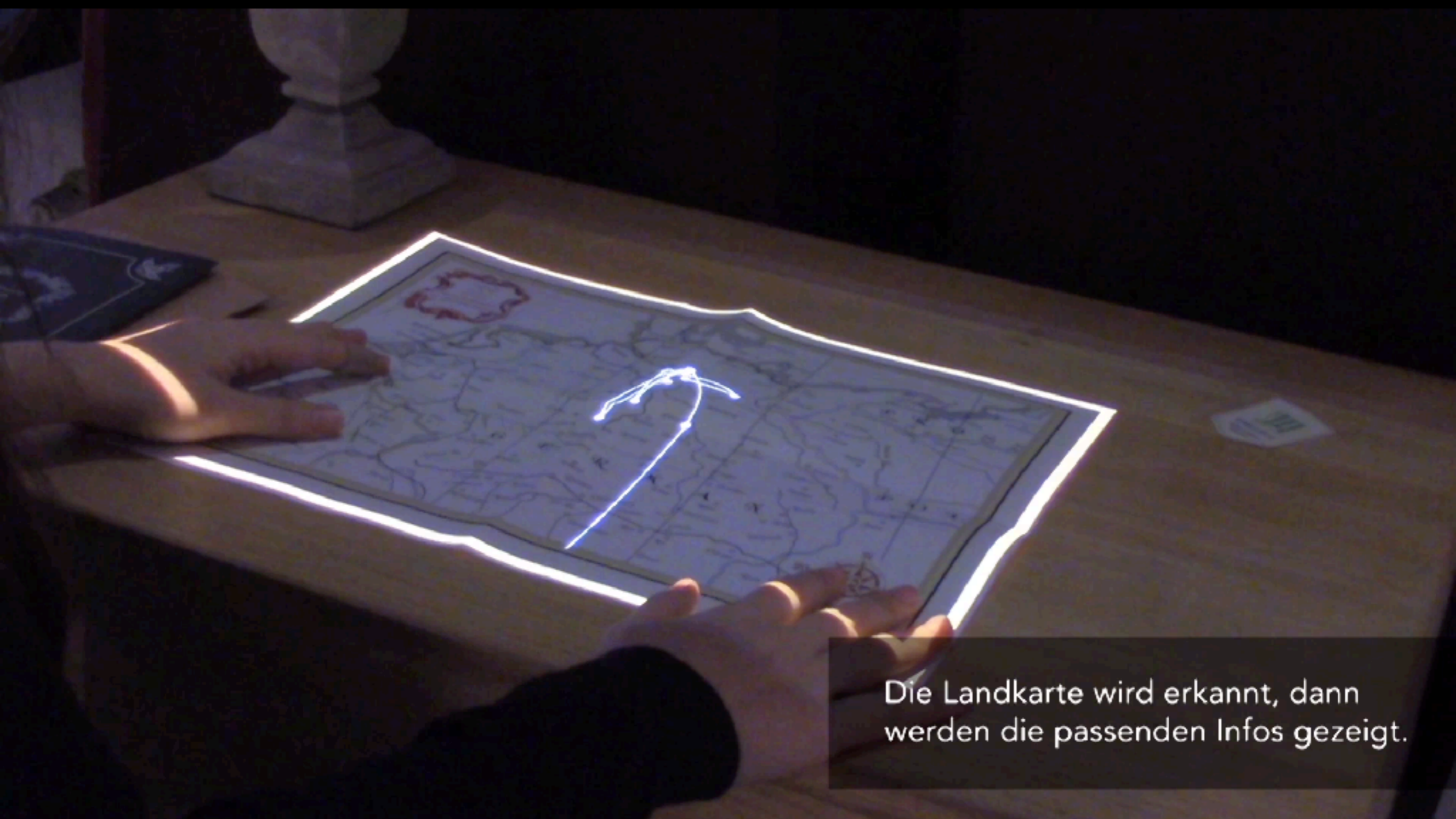

Die Landkarte wird erkannt, dann werden die passenden Infos gezeigt.



»MemoryStamp« – die Sammelleidenschaft des J. Winkelmann

Project WINCKELMANN INTERACTIVE,
Dominik Schumacher, Michael Herzog et. al. 2017
MEMORY STAMP Su Yi, Wanting Sun



»Gemmtable« – das Werk des J. Winkelmann

Project WINCKELMANN INTERACTIVE, Dominik Schumacher, Michael Herzog et. al. 2017
GEMMTABLE Stefanie Vogel, Franziska Juraske, Karina Sommermeier, Till Oeffler

04 Recherche
Problemstellung

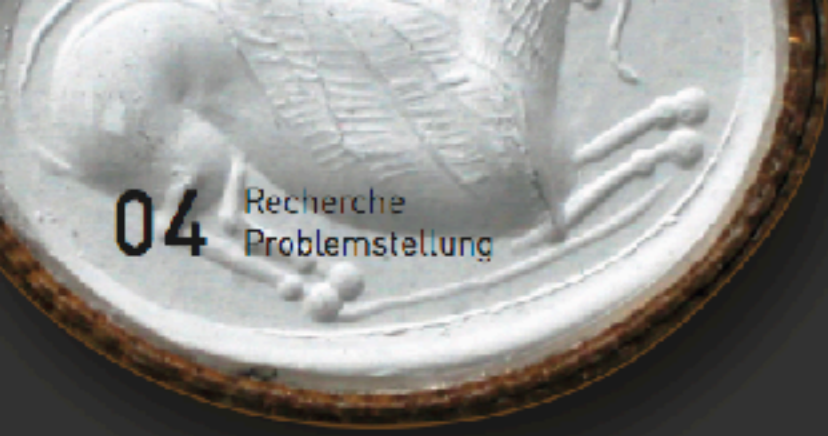

»Gemmtable« – das Werk des J. Winkelmann



»Gemmtable« – das Werk des J. Winkelmann



»Gemmtable« – das Werk des J. Winkelmann



»Gemmtable« – das Werk des J. Winkelmann

28

Ausarbeitung
Screendesign



Ägyptische Hieroglyphen >

Perser, Griechen, Römer >



Mythologie und Götter | Gemme
Kämpfender Typhon

Sardonyx. Der Gigant Typhon, welcher
mit der in einen Hirsch verwandelten
Diana kämpft.

– Johann Joachim Winckelmann –

Tiere

Spielkarten



Spielbrett

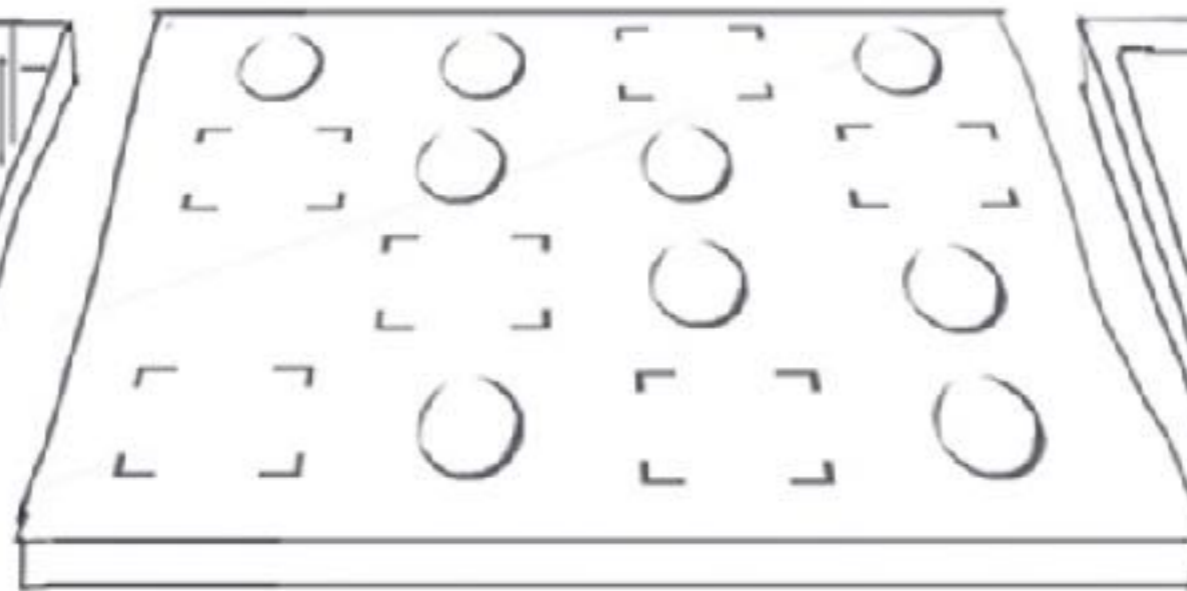

Touchscreen

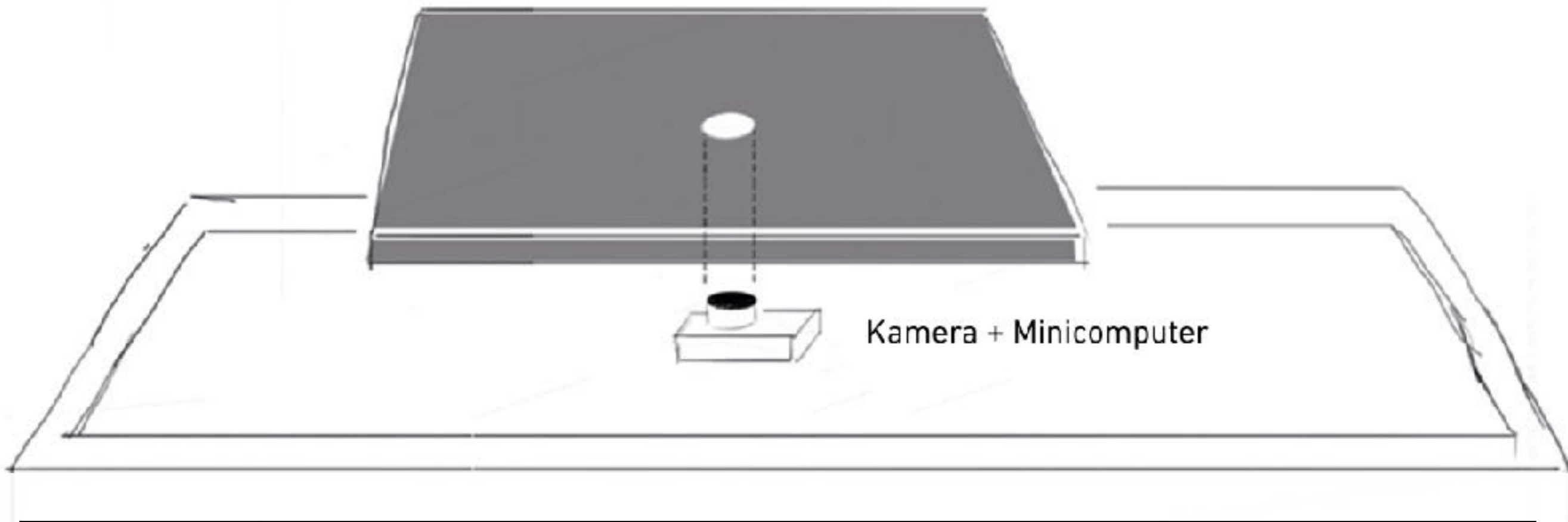
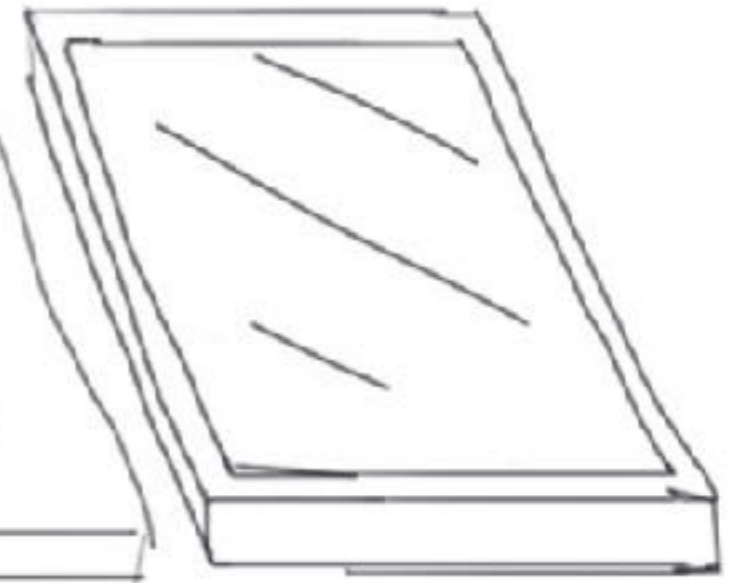

Kamera + Minicomputer



»Gemmtable« – das Werk des J. Winkelmann

Carsten Busch / Christian Kassung /
Jürgen Sieck (Hrsg.)

Kultur und Informatik: Mixed Reality

■ Multimedia

vwh

- ▶ Batz, V., Blümel, F., Falkenberg, J., Haubert, E., Schumacher, D., Herzog, M.A.: Experiencing Artwork with Augmented Reality. Interactive Perception of historical Statue “Belvedere Torso”.
- ▶ Juraske F., Oefler, T., Sommermeier K., Vogel, S., Schumacher, D., Herzog, M.A.: An Interactive Gameboard for Categorization and Examination of Engraved Gems for the Winckelmann Museum.

In: Busch, C., Kassung, C., Sieck, J.: Kultur und Informatik. Mixed Reality, vwh Verlag, 2017